

Internal Memo: Fluke 805 External Sensor

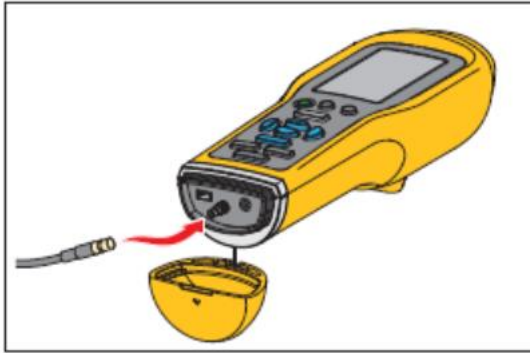

For Fluke Sales Use Only – Do Not Distribute

The Fluke 805 Vibration Meter supports an optional external sensor in applications where the 805 cannot fit into a tight clearance to measure a machine bearing.



If an external sensor is connected, the user will be able to measure overall vibration only (no CF+ and temperature measurement).

Any standard ICP type, (100 mV/g) single channel accelerometer with a subminiature version B (SMB) connector will work with 805's external sensor connection.

If a single axis sensor is detected by the meter, the user is prompted to enter the sensitivity each time before a measurement.

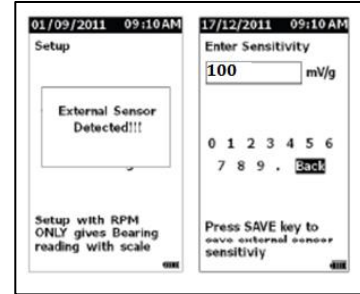

When selecting an external sensor, consider the specifications, the size of the sensor and cable entry so that it can fit into tight places. A top exit sensor with a cable that needs room to bend may not fit onto a bearing with low clearance above the machine. A top exit sensor is fine if all of the machines are open.

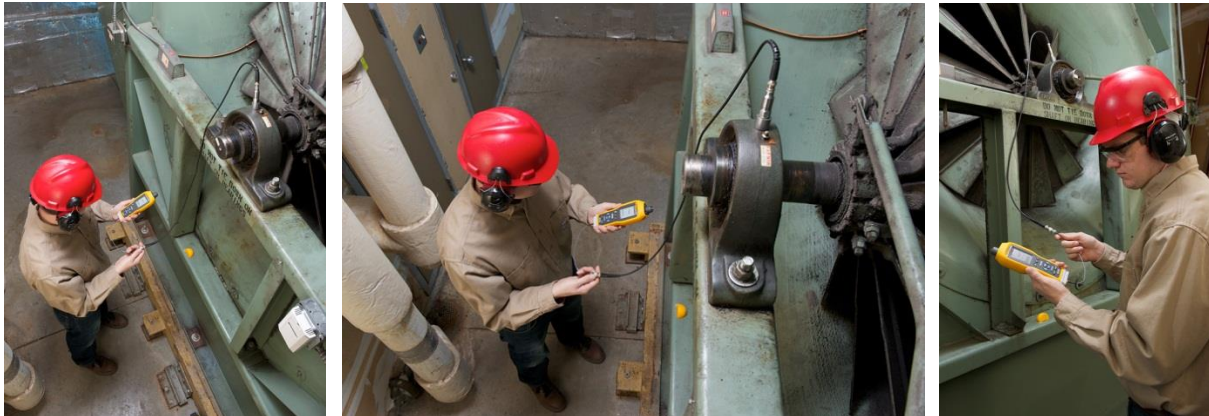

We will soon be releasing a Fluke part number and description for an external sensor. After it is tested, reviewed and approved, a Fluke part number will be available to order the accessory directly from Fluke. Until we do, use the information on the following page will help your distributor or customer purchase a sensor directly from a sensor manufacturer.

For Fluke Sales Use Only – Do Not Distribute

Internal Memo: Fluke 805 External Sensor



For Fluke Sales Use Only – Do Not Distribute

- Sensor: 603C01 for top exit or the 602D01 for side exit (see attached specification sheets)
 603C01 - Top Exit Accelerometer 100mV/G (+/-10%), 2-Pin MIL, .5Hz - 10kHz (+/-3dB)
 602D01 - Side Exit Accelerometer 100mV/G (+/-10%), 2-Pin MIL, .5Hz - 8kHz (+/-3dB)

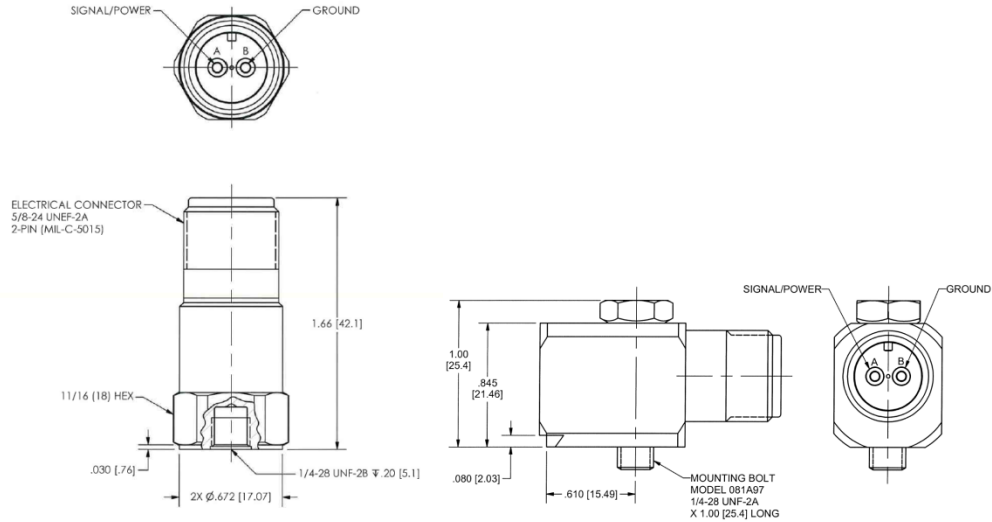

603C01 – Top exit

602D01 – Side exit

- Cable: 044M14 splash proof 2-pin connector to sensor, SMB connector to meter
 Coiled Cable Assembly with 2-Pin MIL connector terminated to SMB Connector 7 foot

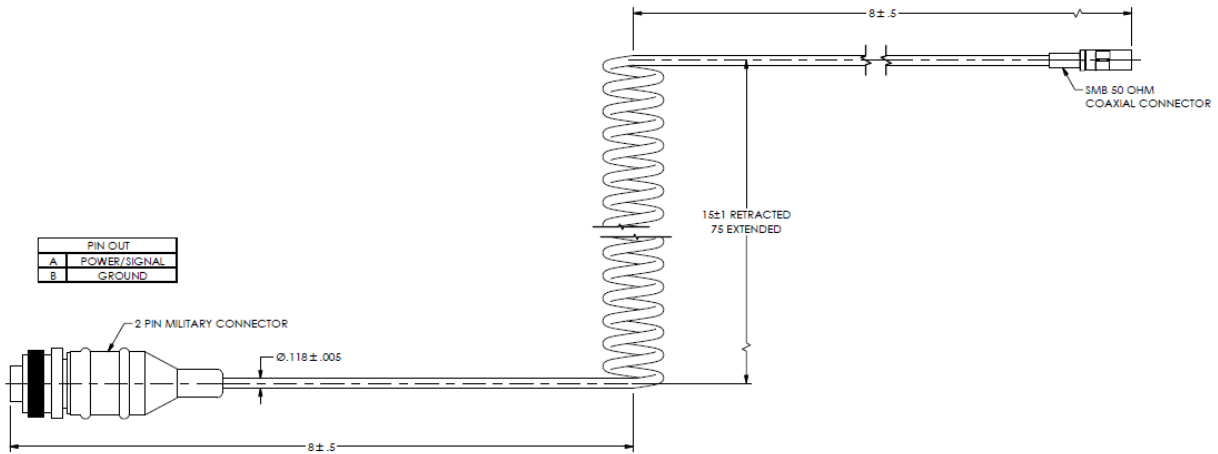

- Magnet for portable mounting: 080A131
 Curved Surface Magnet 1 inch dia. with 35 lb. pull strength and 1/4-28 stud

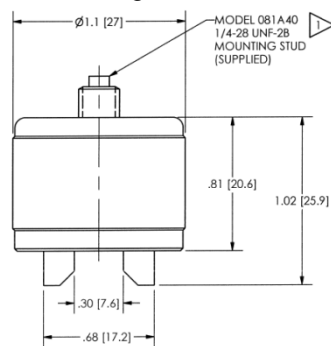

2.) PULL STRENGTH = 35 LBS.

For Fluke Sales Use Only – Do Not Distribute